

### EQUIPMENT

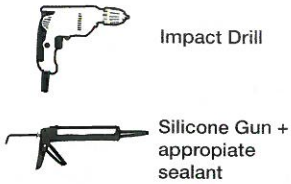

### TOOLS



### IMPORTANT INFORMATION

- ⚠** 1. Product contains a powerful magnet. Avoid contact with metal foreign bodies prior to installation. Keep well clear of electronics and electrical equipment.
2. Carefully read installation Instructions prior to installation. Installing contrary to these instructions risks damage to your floors and door
- Carpeted surfaces:** Allow sufficient clearance of carpet thread and pile when drilling hole into floor to avoid wrapping or binding to drill bit
- Tiled surfaces:** It is recommended to use a diamond coated drill bit to avoid chipping and damage of tiles

## INSTALLATION INSTRUCTIONS

**A**

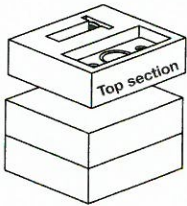

1. Remove top section only of packaging, leave magnet section for now

2. Select:



**B**

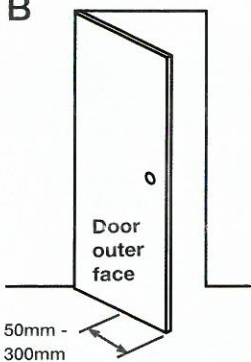

**Mark Pin location on ground**

1. Open door to desired 'stop position'
2. Mark location on floor for pin as per diagram below

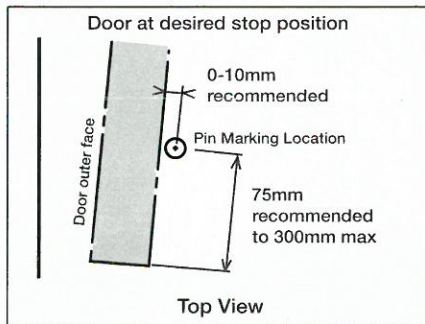

**C**

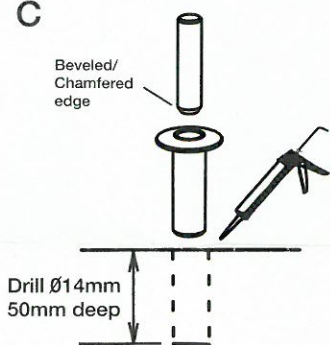

**Install Pin into floor**

1. Drill 14mm hole, 50mm deep
2. Clean hole and area
3. Apply Silicone to Sleeve and insert into hole
4. Once dry, drop pin into Sleeve, chamfered edge first

**D**

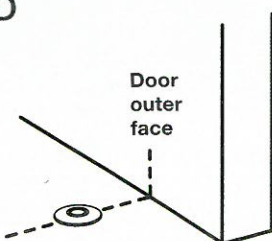

**Mark door for striker fitment**

1. Pass door over Pin Assembly
2. Mark on door where centre of pin passes under door

**E**

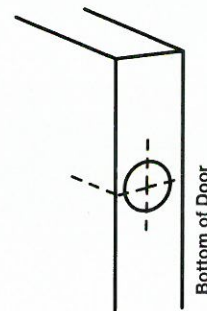

**Drill Hole for Magnet**

1. Remove door from hinges
2. Stand door on edge with latch & knob upwards
3. Continue marking location from step D across bottom of door
4. Mark centre line for drill location
5. Drill diameter 24mm hole with spade bit 25-30mm deep

**F**

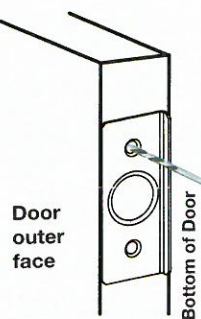

**Drill pilot hole for Striker Screws**

1. Using the Striker as a template, position centre of Striker into Magnet Hole
2. Drill 2 x 3mm diameter holes, 20mm deep

**G**

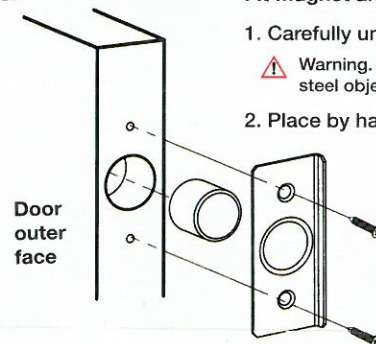

**Fit Magnet and Striker Plate**

1. Carefully unwrap Magnet from packaging  
**⚠** Warning. Powerful magnet, avoid any steel object within at least 200mm
2. Place by hand immediately into hole
3. Fit Striker  
**!!!** Ensure flange of Striker faces the correct direction
4. Tighten Striker Screws

**H**

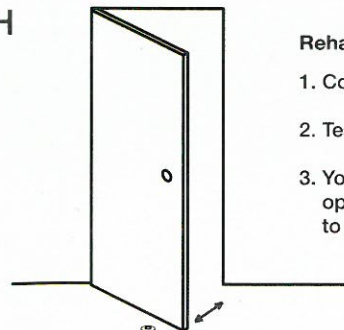

**Rehang Door**

1. Correctly refit door
2. Test by opening door past the pin
3. You should see the door stopped/ open as desired. Pull back on door to release.